

MATERIAL HANDLING

Reel Lifting/Turning

- Manufactured to exceed all ASME B30.20 and OSHA regulations.
- **ALL** material handling equipment proof loaded and shipped with certification paperwork.
- Durable construction ideally suited to jobsite or warehouse use.
- Made in U.S.A.
- Machined to exacting tolerances.

 Prop 65 – See Page 112

Working Load Limit in Pounds*	Part Number	A	B	C	D	Arbor Dia	Weight
500	19455	0.75	1.05	n/a	1.00	1-1/4" - 2"	3
3,000	12782	1.50	2.00	2.75	1.66	2" - 4"	7
4,500	24046	2.00	2.63	2.75	2.38	3" - 6"	14

* Call for specifications on larger sizes and capacities

- Working Load Limit stamped on each lifter.
- Safely allows personnel to flip reels from rolling to non-rolling position quickly and easily.

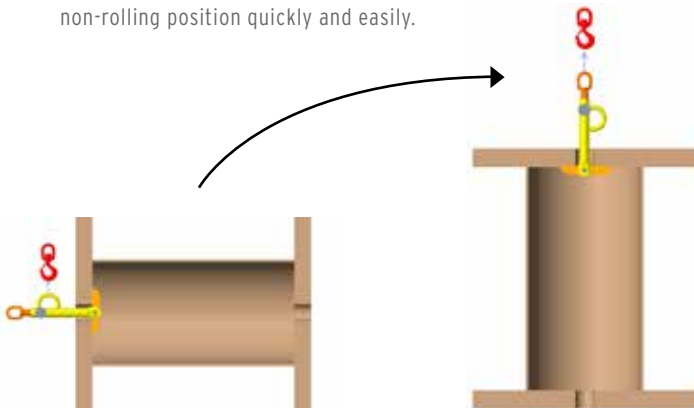

*** TIP UP REEL FROM A ROLLING POSITION TO AN UPRIGHT POSITION, PAY OUT REEL IN UPRIGHT POSITION PART NUMBER 12782 & 13037**

PART NUMBER 19455 NOT FOR TIPPING UP REELS

