

- Manufactured to exceed all ASME B30.20 and OSHA regulations.
- Painted safety yellow for increased visibility.
- **ALL** forklift attachments proof loaded and shipped with certification paperwork.
- Durable construction ideally suited to jobsite or warehouse use.
- Check with manufacturer of your forklift for load capabilities.
- Made in U.S.A.
- Includes forklift restraining tabs.
- Converts forklift into aerial crane. Fork Width : 6"
- Adjustable boom spacing at 48", 60" and 72"
- Boom comes equipped with alloy swivel latching hook.

 Prop 65 – See Page 112

| | Part Number | Weight |
|-----------------|--------------|--------|
| Reach Over Boom | 16055 | 375 |
| Straight Boom | 23312 | 260 |
| Pivot Boom | 25107 | 650 |

OPTIONAL MAST TIE OFF CHAIN:

| Part Number | |
|-------------|-------------------------------------|
| 20410 | Mast Tie Off Chain - 8' Long |



EACH BOOM WITH MAST TIE OFF LOCATION, MAST TIE OFF CHAIN SOLD SEPARATELY

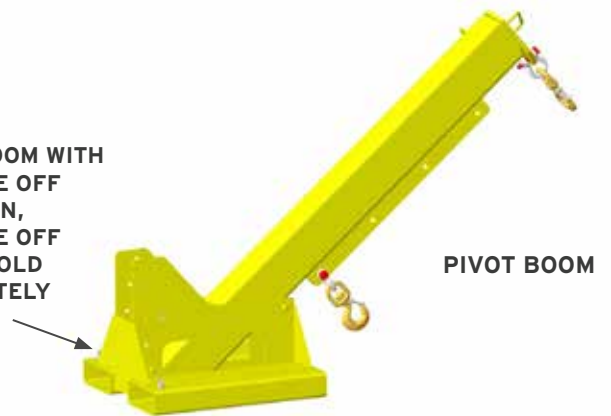

WARNING: M&W fork beams, fork booms, fork pockets and other lift attachments are modifications or additions that affect capacity and/or safe operation of forklifts (powered industrial trucks) and shall not be used without prior written approval from the forklift manufacturer. Capacity, Operation, Maintenance instruction plates, tags, and/or Decals shall be changed accordingly and not provided by M&W.

Reference OSHA 1910.178 | Any forklift attachment must use a tie off restraint to prevent from sliding off forks, sold separately

FORKLIFT ATTACHMENTS

Forklift Adjustable Boom

REACH OVER BOOM

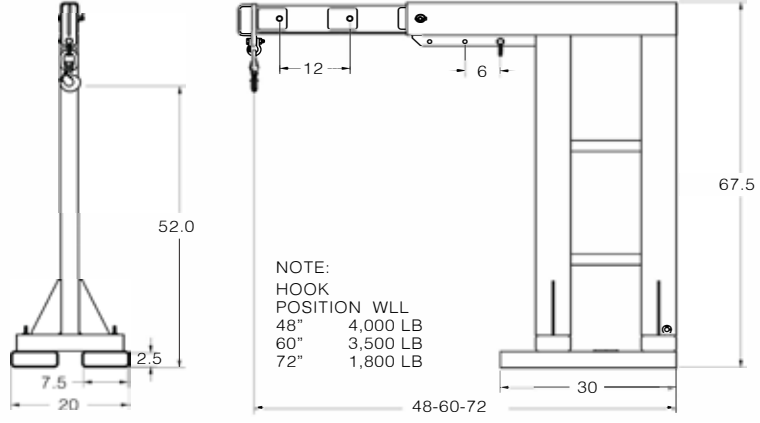

STRAIGHT BOOM

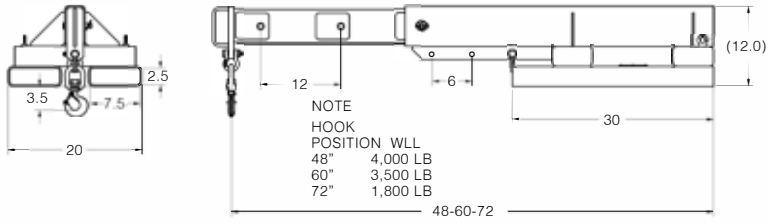

PIVOT BOOM

