

LIFTING HOOKS

Alloy Steel Flat Hooks

- Manufactured to exceed all ASME B30.20 and OSHA regulations.
- Corrosion resistant finish.
- Durable construction ideally suited to jobsite or warehouse use.
- Made in U.S.A.
- **Maximum use temperature is 400° F.**
- ±4% on dimensions.
- Custom designs available - call for engineering.
- Working Load Limit indicated is for the bottom of the hooks - **DO NOT TIP LOAD.**

 Prop 65 – See Page 112

Style A*	Part Number	A	B	C	D	E	F	G	Weight	Working Load Limit in Pounds*
1/4	16397	0.25	4.25	1.00	0.75	0.44	2.38	3.00	1.4	3,200
3/8	16398	0.38	4.50	1.50	1.00	0.44	3.38	4.25	3.4	4,800
1/2	16399	0.50	4.75	1.75	1.25	0.44	4.38	5.25	6.2	6,400

*Larger capacities and custom configurations available. Please call for ordering assistance.

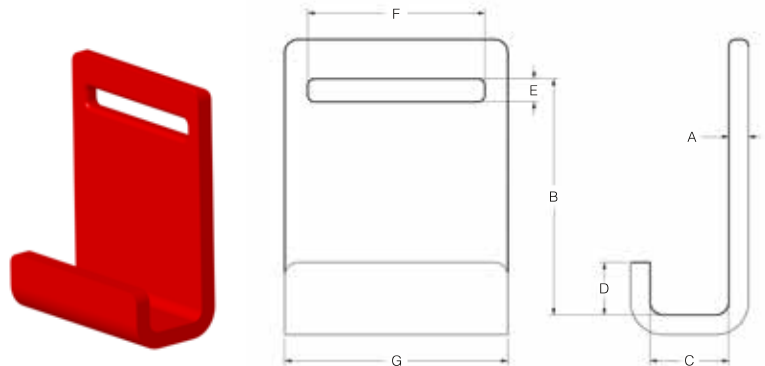

Style B*	Part Number	A	B	C	D	E	F	G	Weight	Working Load Limit in Pounds*
1/4	16400	0.25	4.25	1.00	0.75	0.44	2.38	3.00	1.0	3,200
3/8	16401	0.38	4.50	1.50	1.50	0.44	3.38	4.25	3.3	4,800
1/2	16402	0.50	4.75	1.75	1.75	0.44	4.38	5.25	6.0	6,400

*Larger capacities and custom configurations available. Please call for ordering assistance.

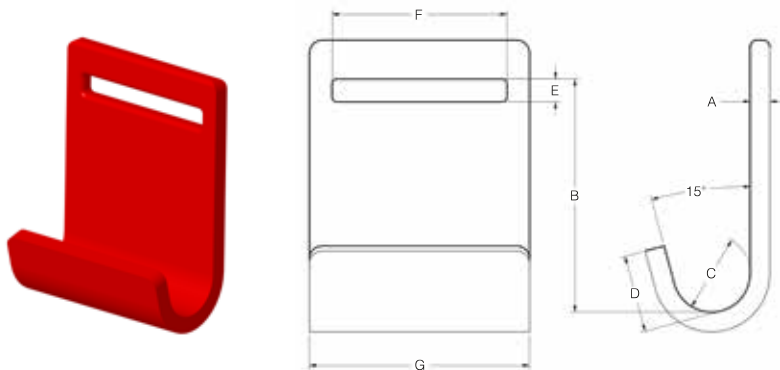

- Manufactured to exceed all ASME B30.20 and OSHA regulations.
- Corrosion resistant finish.
- Durable construction ideally suited to jobsite or warehouse use.
- Made in U.S.A.

- **Maximum use temperature is 400° F.**
- Working Load Limit indicated is for the bottom of the hooks - **DO NOT TIP LOAD.**

 Prop 65 – See Page 112

	Part Number	A	B	C	D	E	F	G	Weight	Working Load Limit in Pounds*
3/16	17618	0.19	1.50	0.25	0.38	0.25	1.25	0.95	0.2	400
3/16	17619	0.19	1.50	0.38	0.50	0.25	1.25	0.95	0.2	300

